

低功耗蓝牙超长电池寿命

	Adv_Interval Time [s]	电池寿命		
		Thin (25mAh)	CR1616 (60mAh)	CR2016 (90mAh)
TC35678	1	0.40	0.97	1.46
TC3567C	3	0.88	2.10	3.16
TC35679				
TC3567D	5	1.14	2.74	4.11

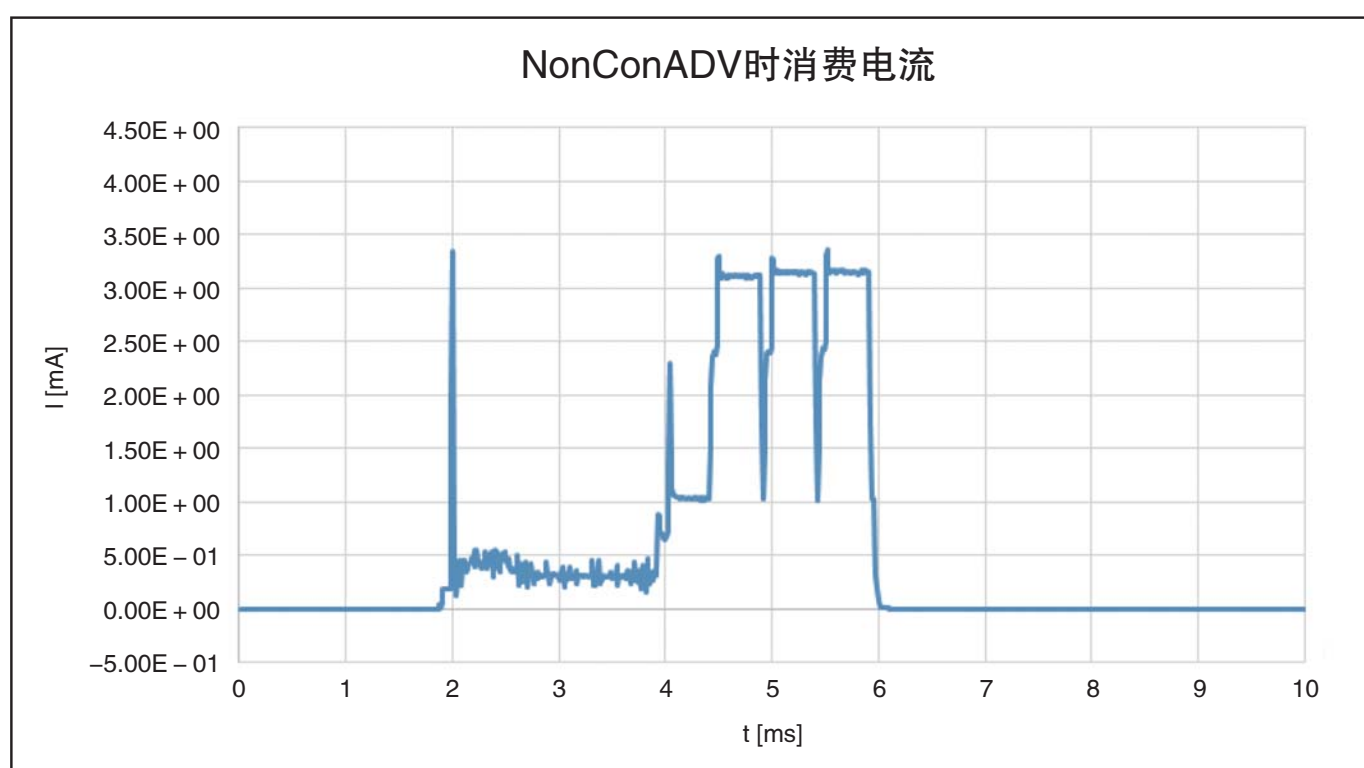
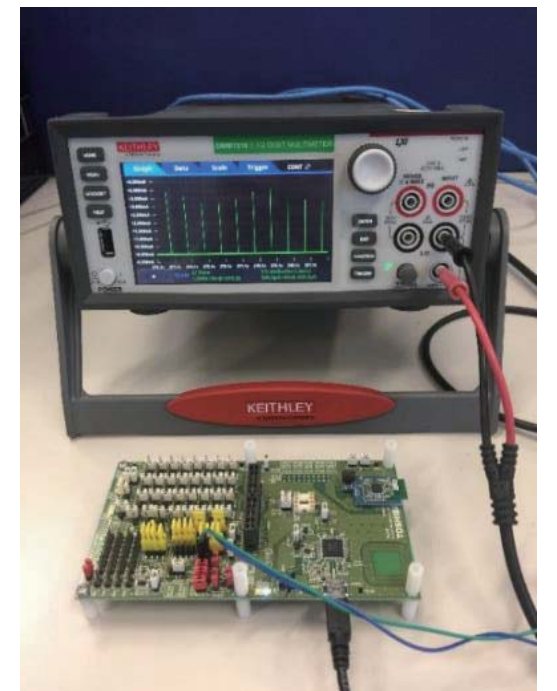

应用场合举例 → 信标

室内定位设备



防丢设备



东芝低功耗蓝牙

TC35678 (QFN40 & QFN60) & TC3567C (QFN40)

TC35679 (QFN40) & TC3567D (QFN40)

框图

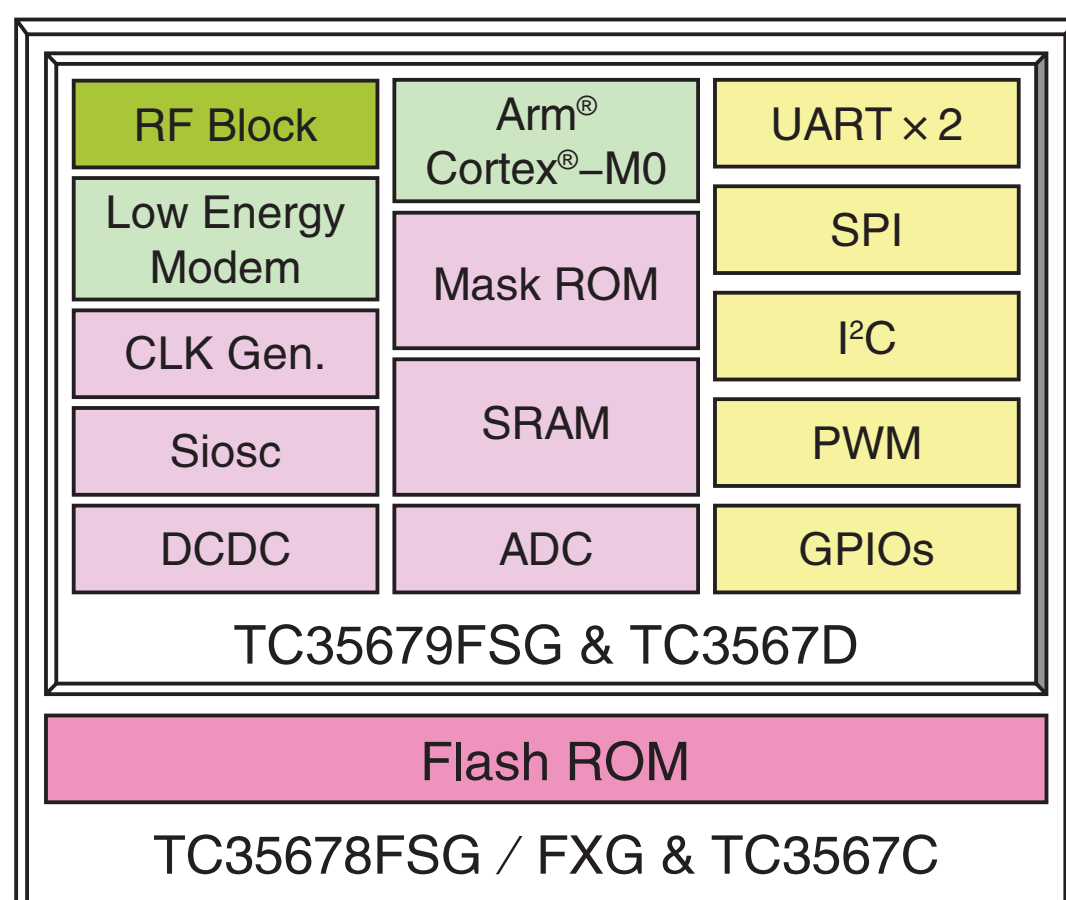

规格 / 特征

- 兼容蓝牙V4.2内核规范，支持SIG mesh组网技术
- 支持蓝牙V4.2内核规范的新特征，数据包扩展和安全链接
- 超低功耗 (TX = 3.3mA @0dB & RX = 3.3mA)
- 内置Arm® Cortex®-M0支持SMD接口
- 接口：
UART: 2ch; SPI & I²C: 1ch;
10位ADC: 7ch (QFN60) / 5ch (QFN40) ;
PWM: 4ch

* Arm和Cortex是Arm有限公司 (或其子公司) 在美国和 / 或其它地区的注册商标。



微博



微信