

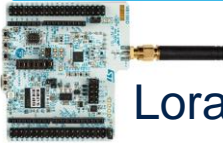

life.augmented

Packing Machine

Automation competence center



EtherNet/IP

EtherCAT

EtherCAT

IO-Link Master

IO-Link Master

IO-Link



Tower Light

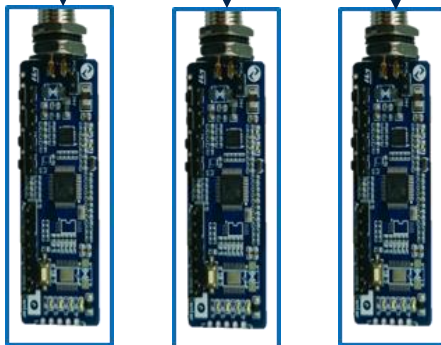

Motor Control



Digital Input



Air-valve Driver



Digital Output



TOF



RFID





HMI+PLC Control system



HMI

EtherNet/IP



PLC

EtherCAT

IO-Link Master

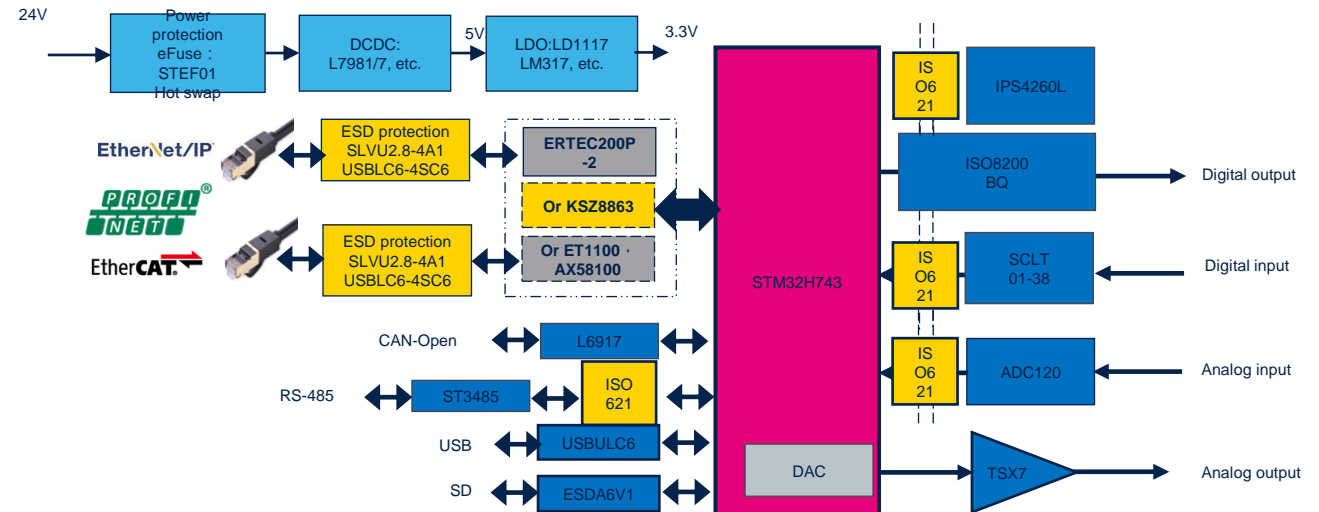
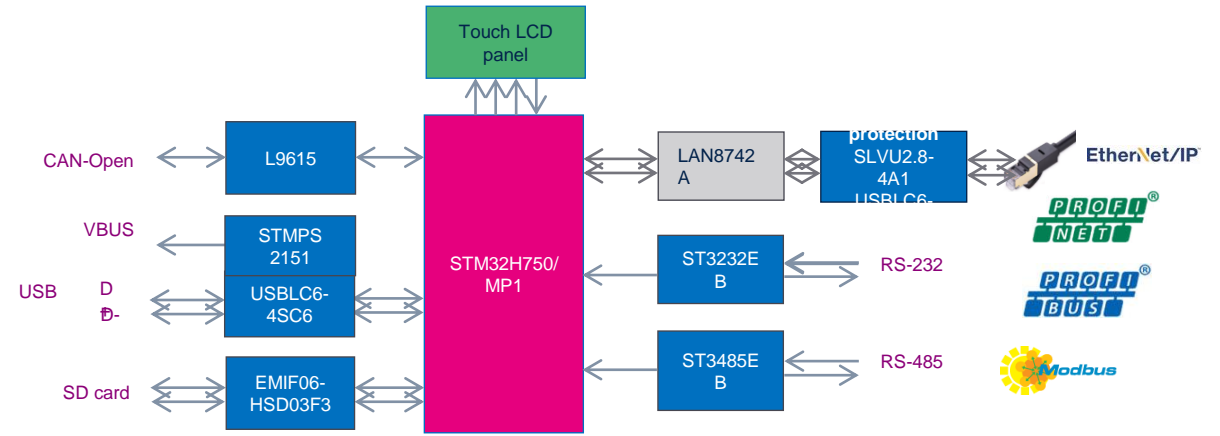



IO-Link master Solution

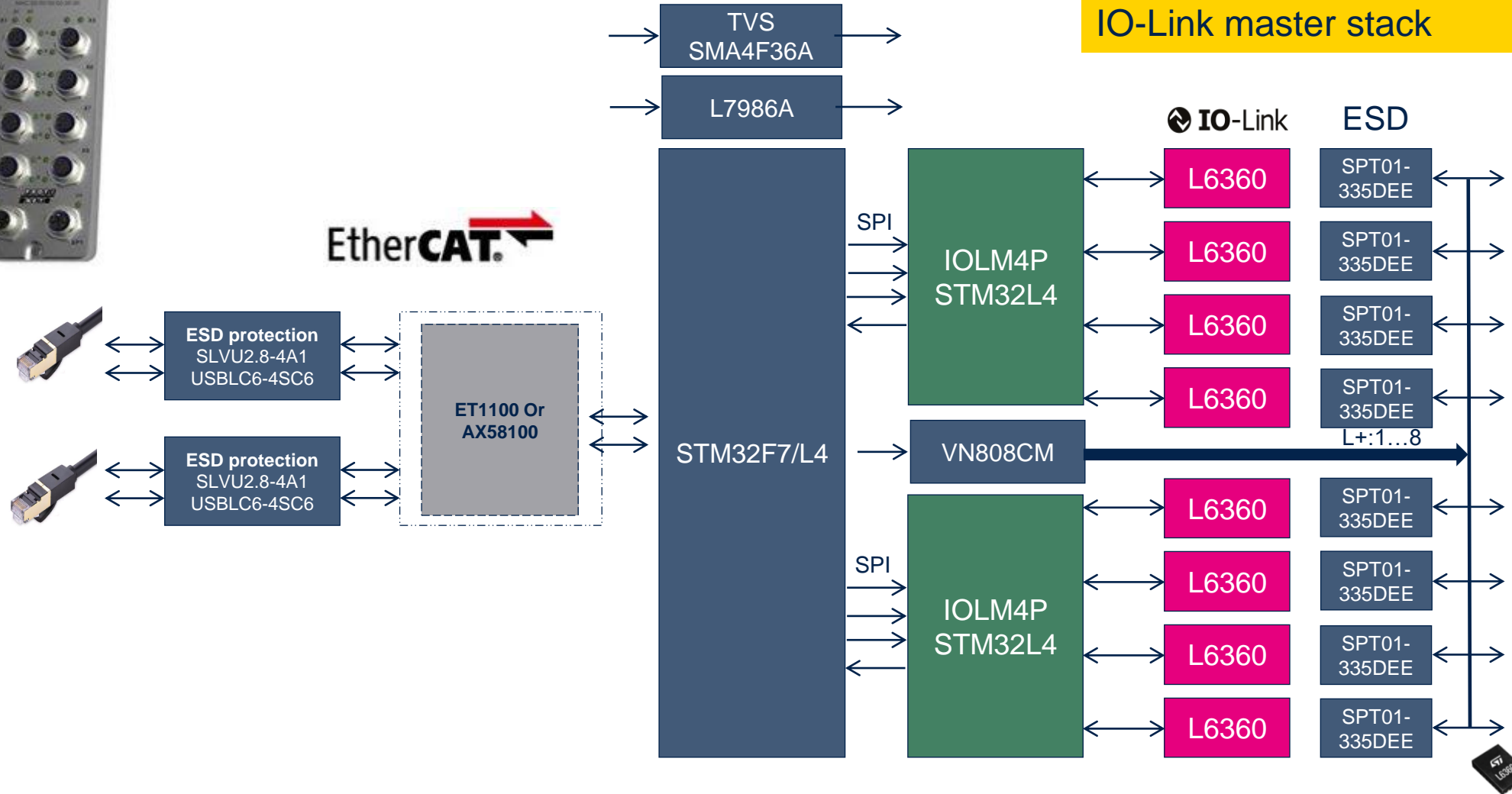



IO-Link Remote IO

- Inovance New IO-Link Remote IO Module: GR20
- Use ST IO-Link solution in the GR20 remote IO:
- STM32F1, L6364Q, 4 pcs IPS4260L

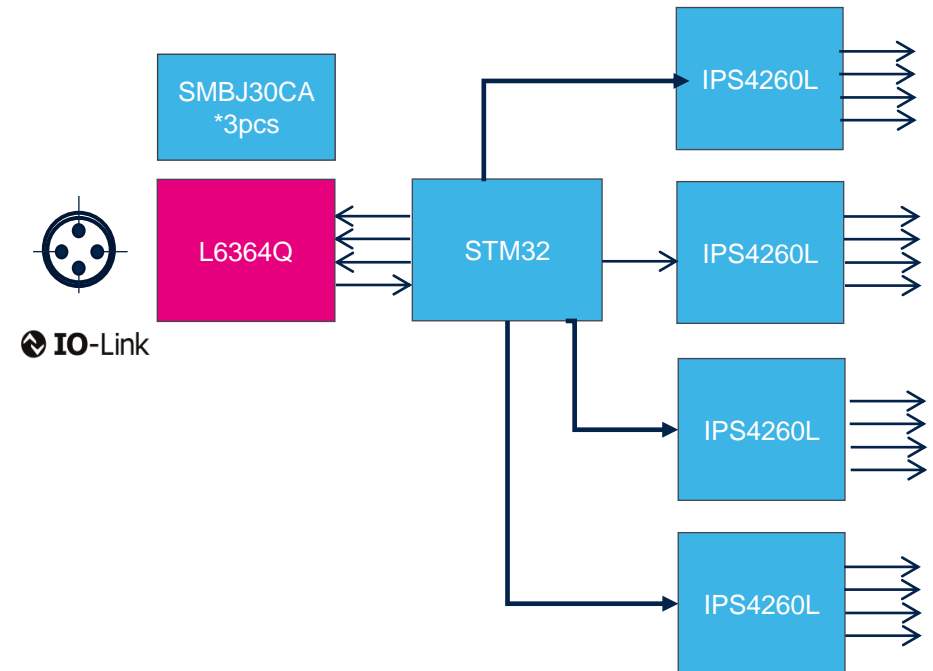
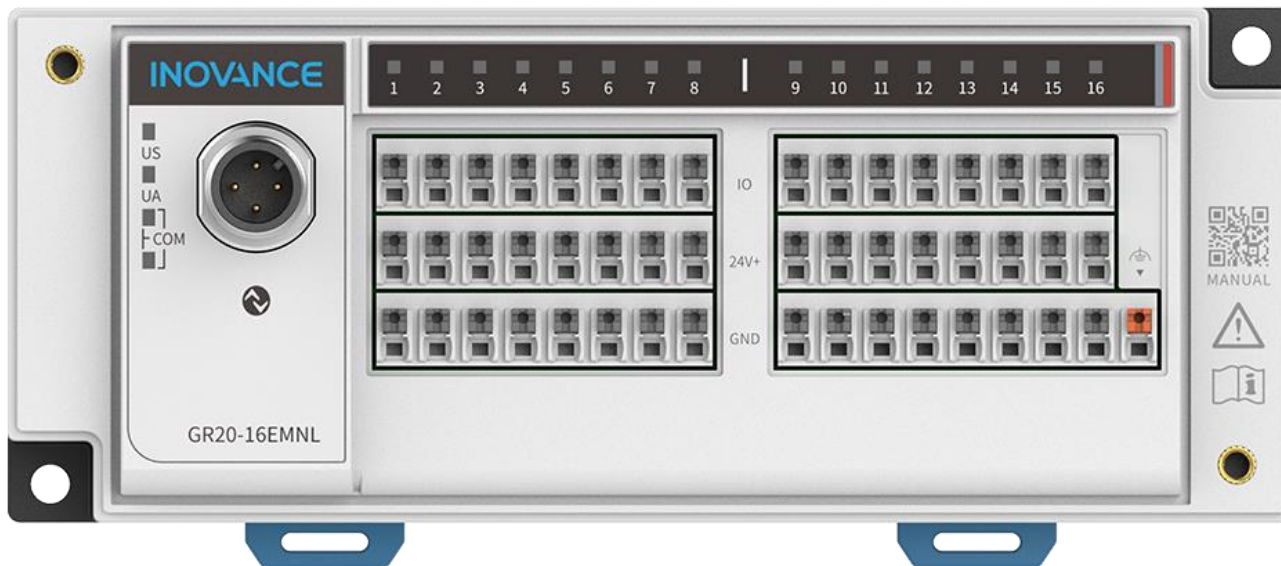

<https://www.inovance.com/product/details?productId=433>

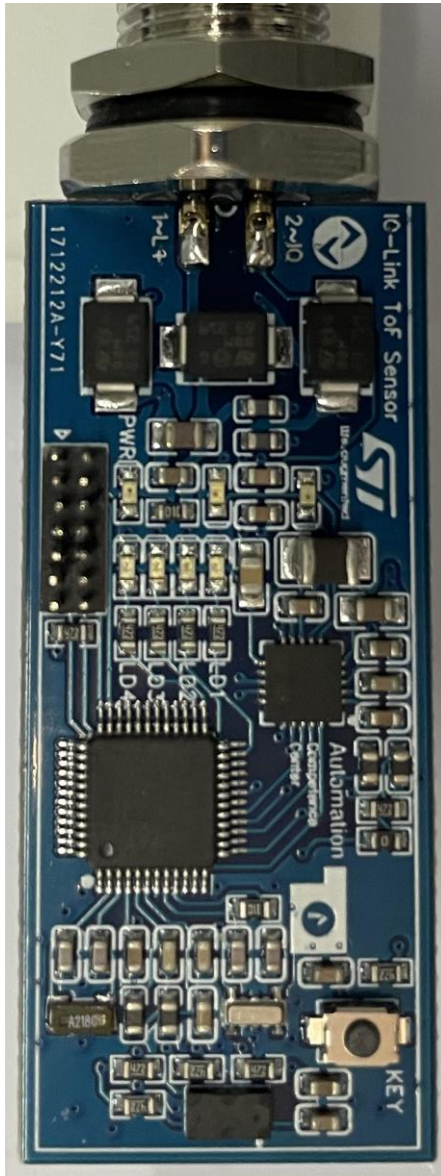

Deliverable: Sch, PCB layout, user guide, GUI, firmware, demo video

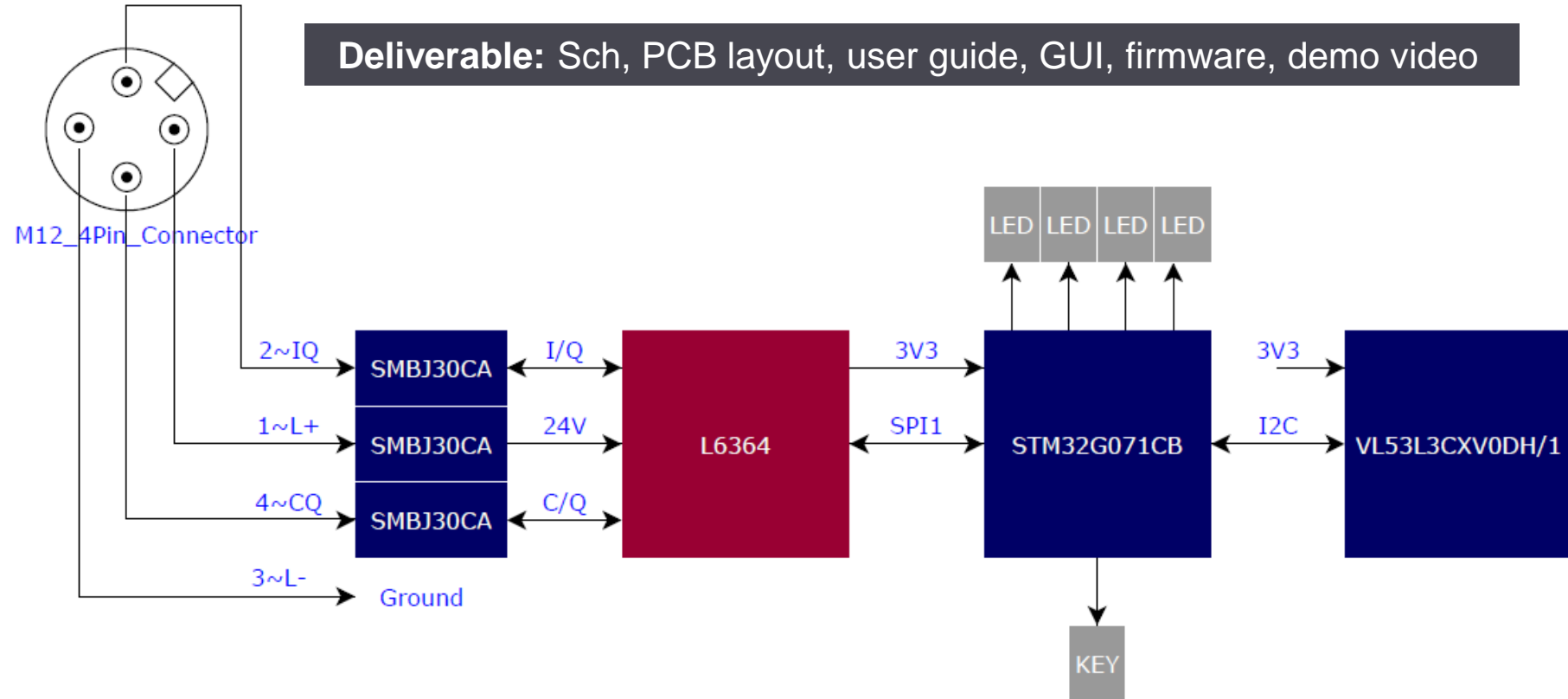



Digital Output

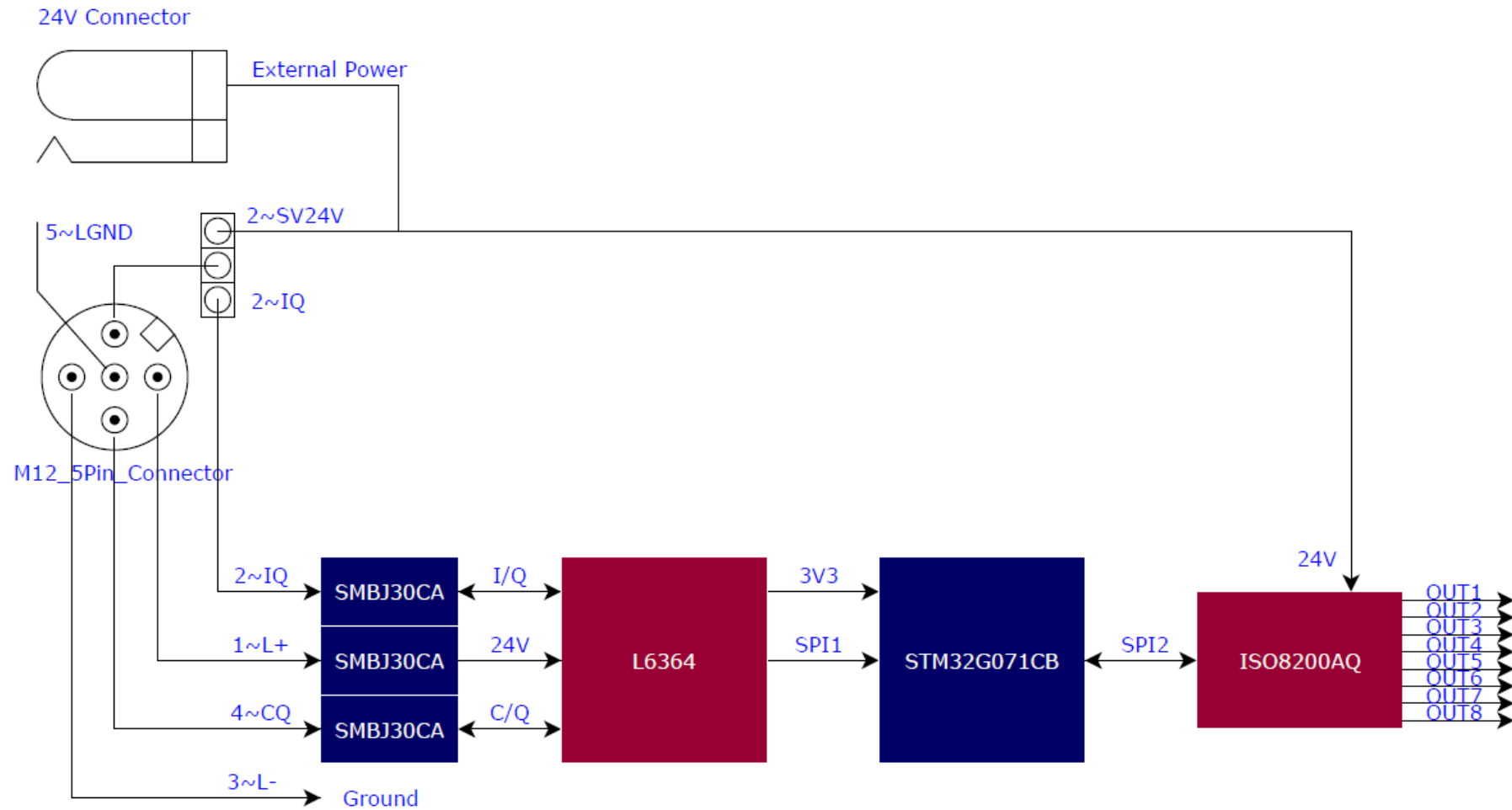



Digital Input

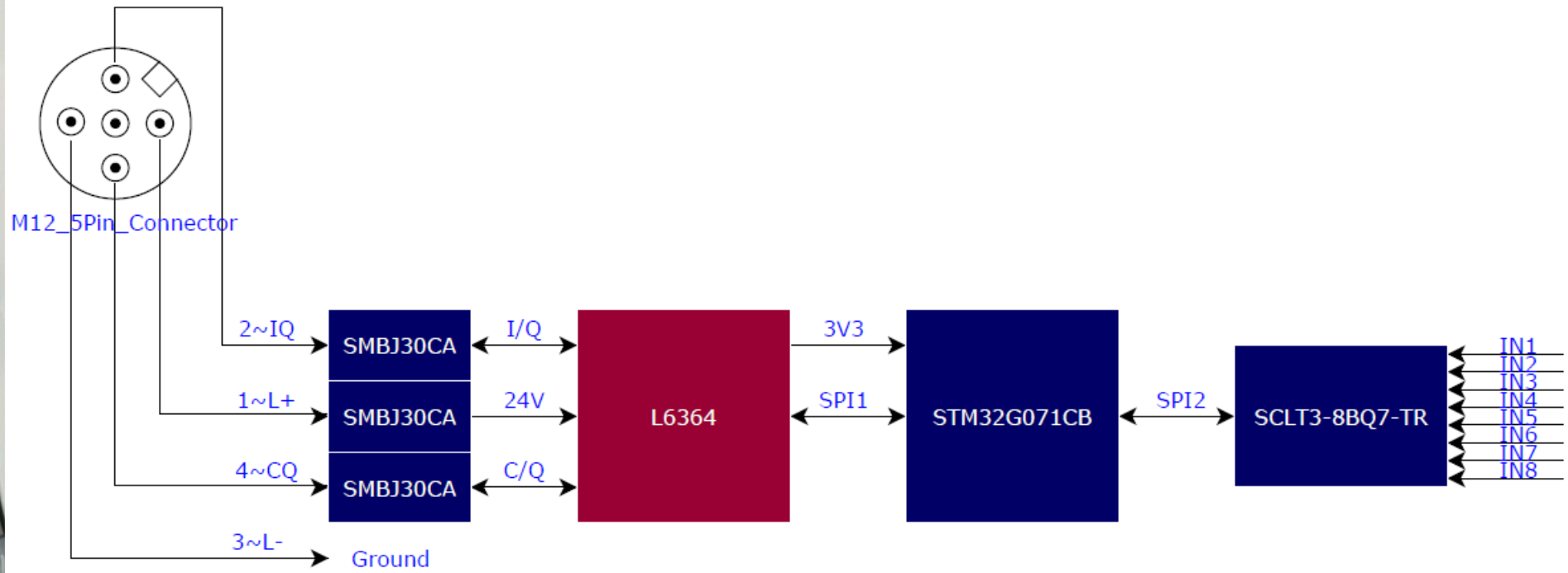



Air-valve Driver

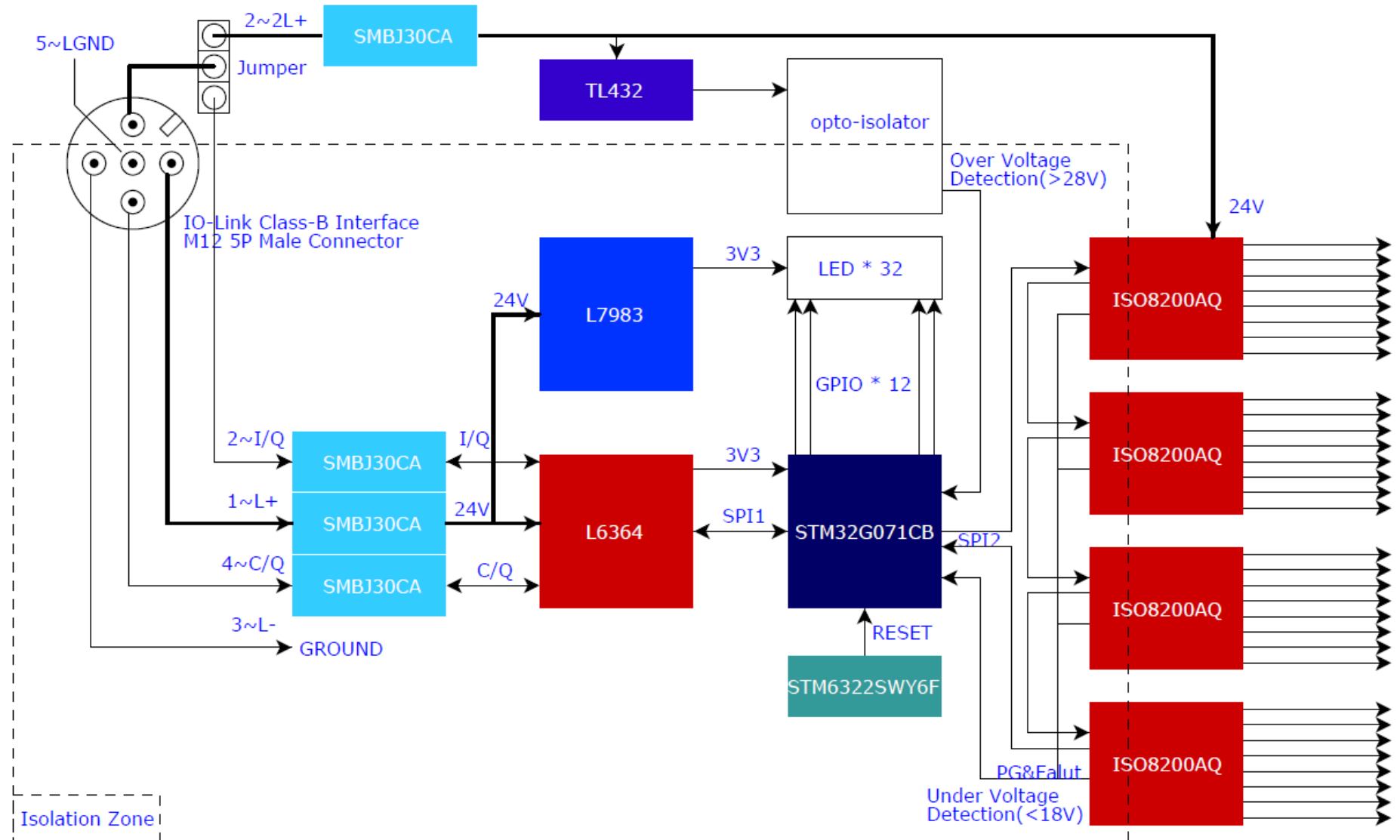
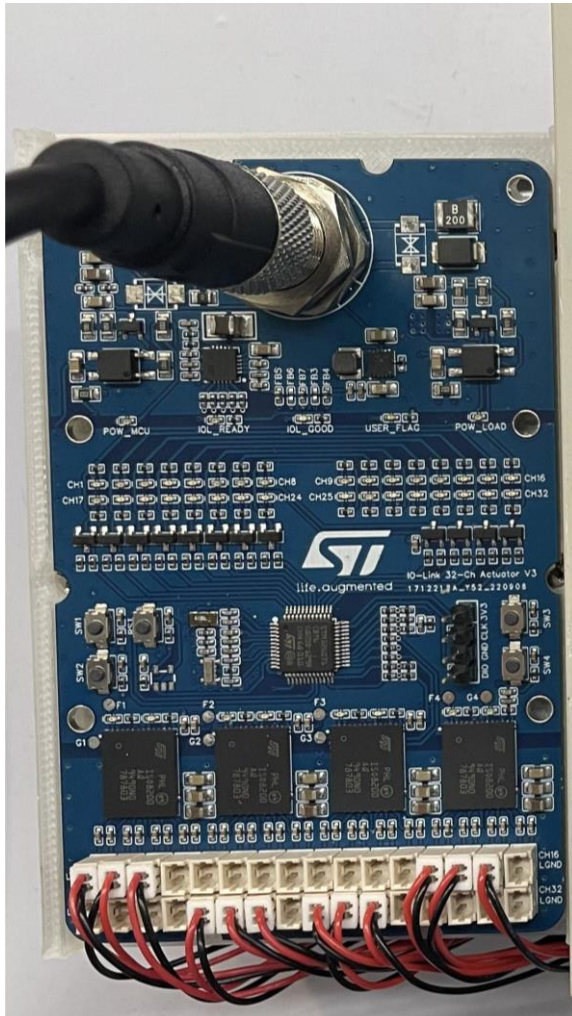



IO-Link Class-A Interface
M12 4P Male Connector

